

European Virtual Campus for Biomedical Engineering EVICAB

J.A. Malmivuo and J.O. Nousiainen

Ragnar Granit Institute, Tampere University of Technology, Tampere, Finland

Abstract— A Curriculum on Biomedical Engineering is established to the Internet for European universities under the project EVICAB. The curriculum will be free access and available free of charge. Therefore it will be available worldwide. EVICAB will make high quality education available for everyone and facilitate the development of the discipline of Biomedical Engineering.

Keywords— e-learning, biomedical engineering

I. INTRODUCTION

Biomedical Engineering is a multidisciplinary field of science covering a large number of sub-specialties. All these are developing very fast. Therefore, for any university, especially for smaller ones, it is difficult to produce and update high quality teaching material in all aspects of the field.

Globalization encourages the students to mobility between universities. The BIOMEDEA project facilitates this by harmonizing the study programs in European universities.

Internet is more and more used as a platform for educational material and student administration. The use of internet makes the geographical distances to disappear.

All this gives strong reasons to develop an education program on the Internet for the use of all European universities.

This is the basis for the project: European Virtual Campus for Biomedical Engineering – EVICAB.

II. EVICAB PROJECT

EVICAB project is funded by the European Commission, Education and Training.

The objective of the project is to develop, build up and evaluate sustainable, dynamical solutions for virtual mobility and e-learning that, according to the Bologna process,

- (i) Mutually support the harmonization of the European higher education programs,
- (ii) Improve the quality of and comparability between the programs, and

- (iii) Advance the post-graduate studies, qualification and certification. These practices will be developed, piloted and evaluated in the field of biomedical engineering and medical physics.

Important goal is that these approaches and mechanisms for virtual e-learning can be extended and transferred from this project also to other disciplines to promote virtual student and teacher mobility and credit transfer between European universities.

III. EVICAB CONSORTIUM

EVICAB is coordinated by the Ragnar Granit Institute of Tampere University of Technology. Professor Jaakko Malmivuo serves as Director of the project and Assistant Professor Juha Nousiainen as coordinator. The other partners are:

- Mediamaisteri Group Ltd, Tampere, Finland
- Department of Biomedical Engineering, Linköping University, Linköping, Sweden
- Biomedical Engineering Center, Tallinn, Tallinn University of Technology
- Institute of Biomedical Engineering, Kaunas University of Technology, Kaunas, Lithuania.
- Department of Biomedical Engineering, Brno University of Technology, Brno, Czech Republic.

EVICAB welcomes interested institutes to join as associate partners. This means that the associate partners may participate the main meetings and they will get all the relevant information and may use the EVICAB material even before it is in public use. We also hope that the associate partners active participate in producing teaching material to EVICAB.

IV. IDEA OF THE EVICAB

The fundamental idea of the EVICAB is that it offers a platform for Biomedical Engineering curriculum on the Internet. Teachers, who are experienced and recognized experts in their field, are encouraged to submit full e-courses, course modules and other teaching material to EVICAB. The material may include many different formats

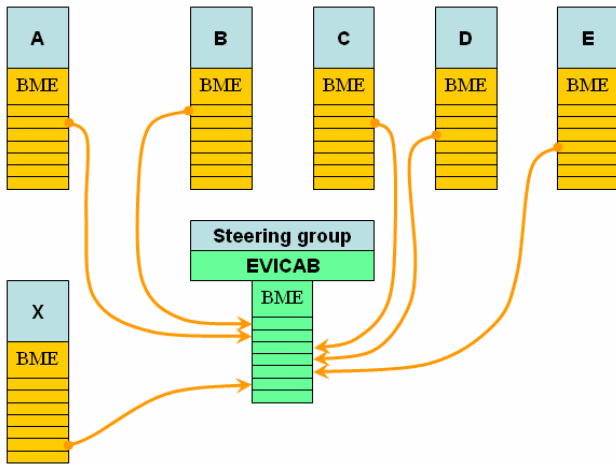

Fig. 1. EVICAB is built from the BME Programs of the partner universities A-E. Other universities (X) may also contribute.

like video lectures, PowerPoint slides, pdf-files, Word files etc.

EVICAB is not a university. The course and student administration continue in the universities as usual: The teacher, responsible of the course/study program, may select from the EVICAB courses for the BME curriculum of the university. The students study the course either as ordinary lecturing course with the EVICAB material supporting the lectures or the course may be partially or solely studied from EVICAB. The students, or anyone even outside the university, may study EVICAB courses to add their competence in Biomedical Engineering.

The EVICAB has an Administrative Board which administers the EVICAB curriculum. The board accepts courses of sufficient scientific, pedagogical and technical quality. The board may also invite experts to provide course material to the EVICAB. Courses which apparently are of low quality, either out of date, lower quality than competing courses and not appreciated by the users of the EVICAB will be deleted. Active feedback from the users of EVICAB, both teachers and students, is essential. All this will be realized by utilizing a dynamical quality assurance system.

V. THE ROLE OF EVICAB IN E-LEARNING

In its completed form, EVICAB will have impact on all main levels of the education process:

For students:

- virtual mobility
- e-courses

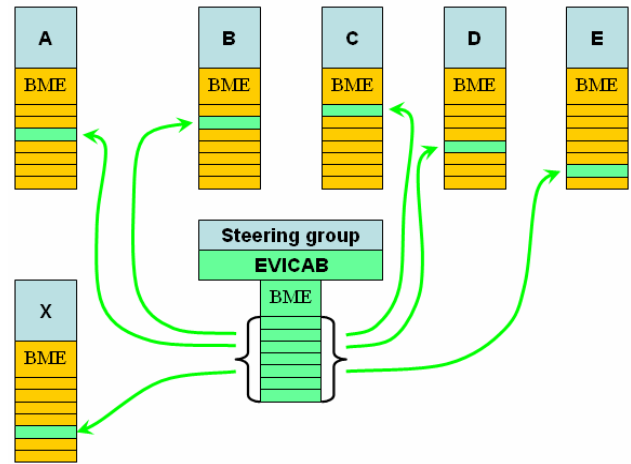

Fig. 21. Universities take one or more BME Courses or the whole curriculum from the EVICAB to complete their study programs.

For teachers:

- teaching material and other resources
- e-learning methods
- support for e-course development

For the study programs:

- improved quality
- harmonization of the degree studies

General:

- model applicable also for other disciplines

VI. MOODLE PLATFORM

In EVICAB the Moodle program has been selected to serve as platform for the learning environment and learning management. Moodle is an open source program and therefore suitable to the EVICAB philosophy of free access. Moodle is also very versatile program offering a wide variety of tools for various pedagogical and administrative tasks. However, other open source platforms may also be used.

VII. INTERNET EXAMINATION

Another successful innovation and application in our e-learning activities has been the Internet examination.

In the Internet examination the students make the exam in a computer class. This may be performed simultaneously

in several universities. Therefore the students do not need to travel to the location where the course was given.

The students open the Moodle program at the time of the examination and find the examination questions from there. We usually allow the students to use all the material available on the Internet. This requires that instead of asking "What is ...?" the questions shall be formulated so that they indicate that the student has understood the topic and is able to apply this information. The only thing which is not allowed is communication with some other person via e-mail etc. during the examination.

VIII. WHY TO PROVIDE COURSES TO EVICAB?

EVICAB will become an important teaching and learning method only if it is available free of charge and worldwide. As a consequence, the learning material should be provided free of charge.

Why experienced and competent teachers should provide such material without charge and without royalties? Acceptance of a course by EVICAB will be a certificate for quality. Worldwide distribution to all university students will give exceptional publicity for the author and his/her university. All this will facilitate the sales of traditional teaching material produced by the course author. This will also attract international students from other countries all over the world to apply to the home university of the material author. We already have experience which has proven these issues to be realistic.

The Internet has dramatically changed the distribution of information. Distribution is world wide, real time and free of delivery costs. The technology also supports wide variety of attractive presentation modalities. All this ensures wide audience and publicity for the material on the Internet. For

instance, the Wikipedia dictionary serves as a successful example of this new era of information delivery. On the basis of this publicity it is possible to create markets also for traditional printed educational material.

IX. CONCLUSION

In future, the teaching and learning will mainly be based on Internet. The ideas and the technology of EVICAB are not limited only for application on Biomedical Engineering but it may be applied to all fields and levels of education. EVICAB will be the forerunner and show the way to more efficient and high quality education.

ACKNOWLEDGMENT

Financial support from the European Commission and the Ragnar Granit Foundation is acknowledged.

REFERENCES

1. EVICAB at <http://www.evicab.eu>
2. Moodle at <http://www.moodle.fi/evicab/moodle/>
3. Malmivuo J, Plonsey R (1995) Bioelectromagnetism. at <http://www.tut.fi/~malmivuo/bem/bembook/>

Author: Jaakko Malmivuo
 Institute: Ragnar Granit Institute
 Street: Korkeakoulunkatu 3
 City: Tampere
 Country: Finland
 Email: jaakko.malmivuo@tut.fi